

| REVISIONS | | | | |
|-----------|------|-----------------|-------------|----------|
| ZONE | REV. | DESCRIPTION | DATE | APPROVED |
| | A | INITIAL RELEASE | 07-Feb-2021 | MN |

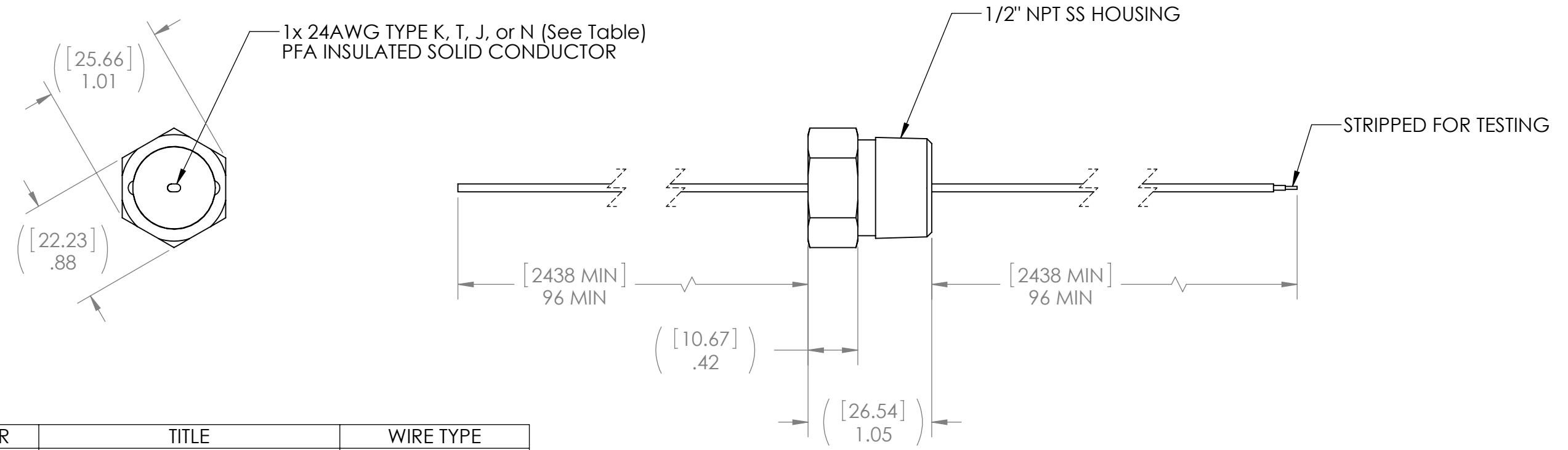

| PART NUMBER | TITLE | WIRE TYPE |
|-------------|---|-----------|
| 60671-K | CABLE SEAL 1/2NPT SS316 (1P)#24 TYPE K PFA 96-96 | TYPE K |
| 60671-T | CABLE SEAL 1/2NPT SS316 (1P)#24 TYPE T PFA 96-96 | TYPE T |
| 60671-J | CABLE SEAL 1/2NPT SS316 (1P)#24 TYPE J PFA 96-96 | TYPE J |
| 60671-N | CABLE SEAL 1/2NPT SS316 (1P)#24 TYPE N PFA 96-96 | TYPE N |

- NOTES:
1. HELIUM LEAK TEST @ 1 ATM 1X10⁻⁸ STD-CC/SEC OR BETTER, VACUUM ON THREAD SIDE.
 2. PRESSURE TEST 1,000 PSI NO BUBBLES 3 MINUTES WITH PRESSURE ON THREAD SIDE.
 3. HYPOT 300VDC 300 MEGOHMS 1 SECOND MINIMUM.
 4. SEAL OPERATING TEMPERATURE -20C TO 130C (WIRE TEMPERATURE RATING IS 250C).
 5. DIMENSIONS ARE INCHES [MILLIMETERS], MILLIMETERS SHOWN FOR REFERENCE ONLY.
 6. CUSTOM SIZES, WIRE OR FIBER OPTIC CONFIGURATIONS, & TESTS AVAILABLE, PLEASE CONTACT RHS FOR MORE INFORMATION.

| | | | | |
|--------------------------------------|---|--------------|--|-----------|
| UNLESS OTHERWISE SPECIFIED: | NAME | DATE | | |
| DIMENSIONS ARE IN INCHES | DRAWN | MM | | 07FEB2021 |
| TOLERANCES: | CHECKED | | | |
| FRACTIONAL ±1/16 | ENG APPR. | MN | | 07FEB2021 |
| ANGULAR ±.5 | MFG APPR. | | | |
| X. ±1 .X ±.1 | Q.A. | | | |
| .XX ±.02 .XXX ±.005 | PROPRIETARY AND CONFIDENTIAL THE INFORMATION CONTAINED IN THIS DRAWING IS THE SOLE PROPERTY OF RELIABLE HERMETIC SEALS. ANY REPRODUCTION IN PART OR AS A WHOLE WITHOUT THE WRITTEN PERMISSION OF RELIABLE HERMETIC SEALS IS PROHIBITED. | | TITLE: CABLE SEAL 1/2NPT SS316 (1P)#24 TYPE (SEE TABLE) PFA 96-96 | |
| INTERPRET GEOMETRIC TOLERANCING PER: | SIZE | DWG. NO. | REV | |
| MATERIAL | B | 60677 | A | |
| SEE ABOVE | SCALE: 1:1 | WEIGHT: | SHEET 1 OF 1 | |
| FINISH | | | | |
| N/A | | | | |
| DO NOT SCALE DRAWING | | | | |