

REVISIONS				
ZONE	REV.	DESCRIPTION	DATE	APPROVED
	A	INITIAL RELEASE	1/13/2014	BS
	B	FLIPPED ONE SET OF USB CONNECTOR SO THEY FACED THE SAME WAY	1/14/2014	BS

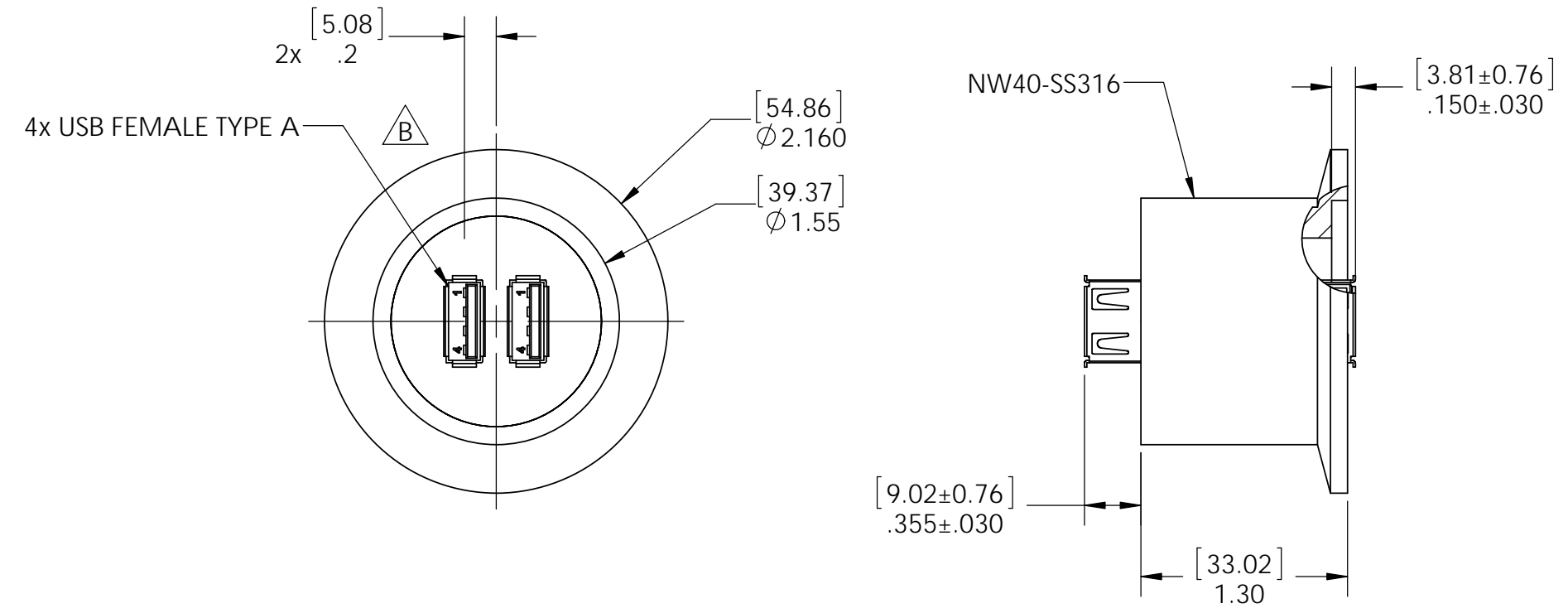

2x PIN OUT	
USB ATM	USB VACUUM
1	1
2	2
3	3
4	4

- NOTES:
1. HELIUM LEAK TEST @ 1 ATM 1×10^{-8} STD-CC/SEC OR BETTER, VACUUM ON THE FLANGE SIDE.
 2. HYPOT 100VDC 100 MEGOHMS .01 SECOND MINIMUM CONDUCTOR TO CONDUCTOR AND HOUSING.
 3. SEAL OPERATING TEMPERATURE -20C TO 130C (CONNECTOR LIMITED TO 85C).
 4. DIMENSIONS ARE INCHES [MILLIMETERS], MILLIMETERS SHOWN FOR REFERENCE ONLY.
 5. CUSTOM SIZES, WIRE OR FIBER OPTIC CONFIGURATIONS, & TESTS AVAILABLE, PLEASE CONTACT RHS FOR MORE INFORMATION.

UNLESS OTHERWISE SPECIFIED:	NAME	DATE	 Jersey City, NJ, USA 888-747-3250
DIMENSIONS ARE IN INCHES	DRAWN	MM 1/13/14	
TOLERANCES:	CHECKED	BS 1/13/14	
FRACTIONAL $\pm 1/16$	ENG APPR.	MM 1/13/14	
ANGULAR $\pm .5$	MFG APPR.		
X. ± 1 .X ± 1	Q.A.		TITLE: CONNECTOR SEAL NW40 316SS (2)USB A RCPT
.XX $\pm .02$.XXX $\pm .005$	PROPRIETARY AND CONFIDENTIAL THE INFORMATION CONTAINED IN THIS DRAWING IS THE SOLE PROPERTY OF RELIABLE HERMETIC SEALS. ANY REPRODUCTION IN PART OR AS A WHOLE WITHOUT THE WRITTEN PERMISSION OF RELIABLE HERMETIC SEALS IS PROHIBITED.		SIZE DWG. NO. REV
INTERPRET GEOMETRIC TOLERANCING PER:			B 80049 B
MATERIAL NOTED			SCALE: 1:1 WEIGHT: SHEET 1 OF 1
FINISH			
DO NOT SCALE DRAWING			