

REVISIONS

ZONE	REV.	DESCRIPTION	DATE	APPROVED
	A	INITIAL RELEASE	11Apr2022	MN
	B	UPDATED EPOXY LENGTH	03May2022	MN

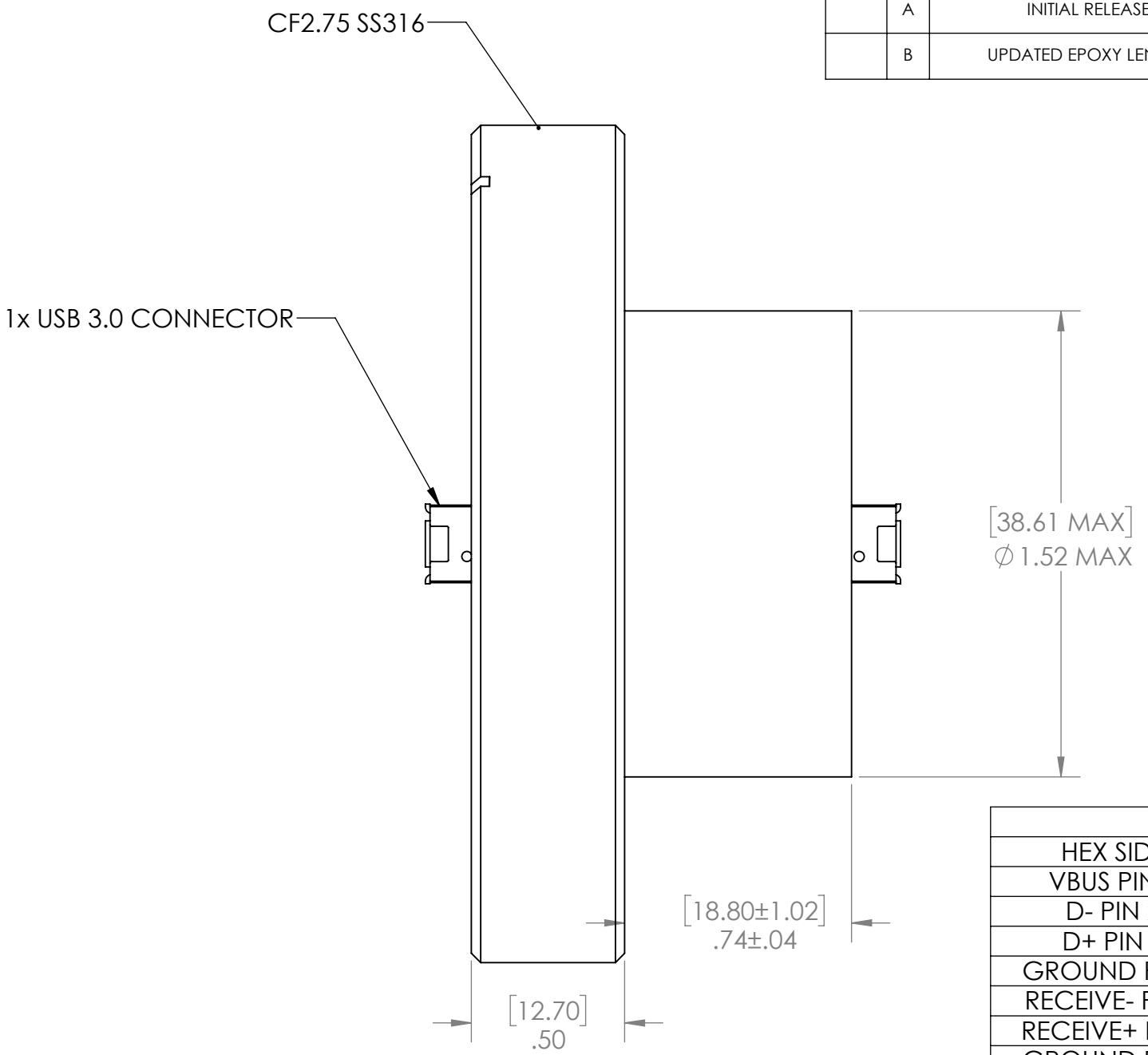
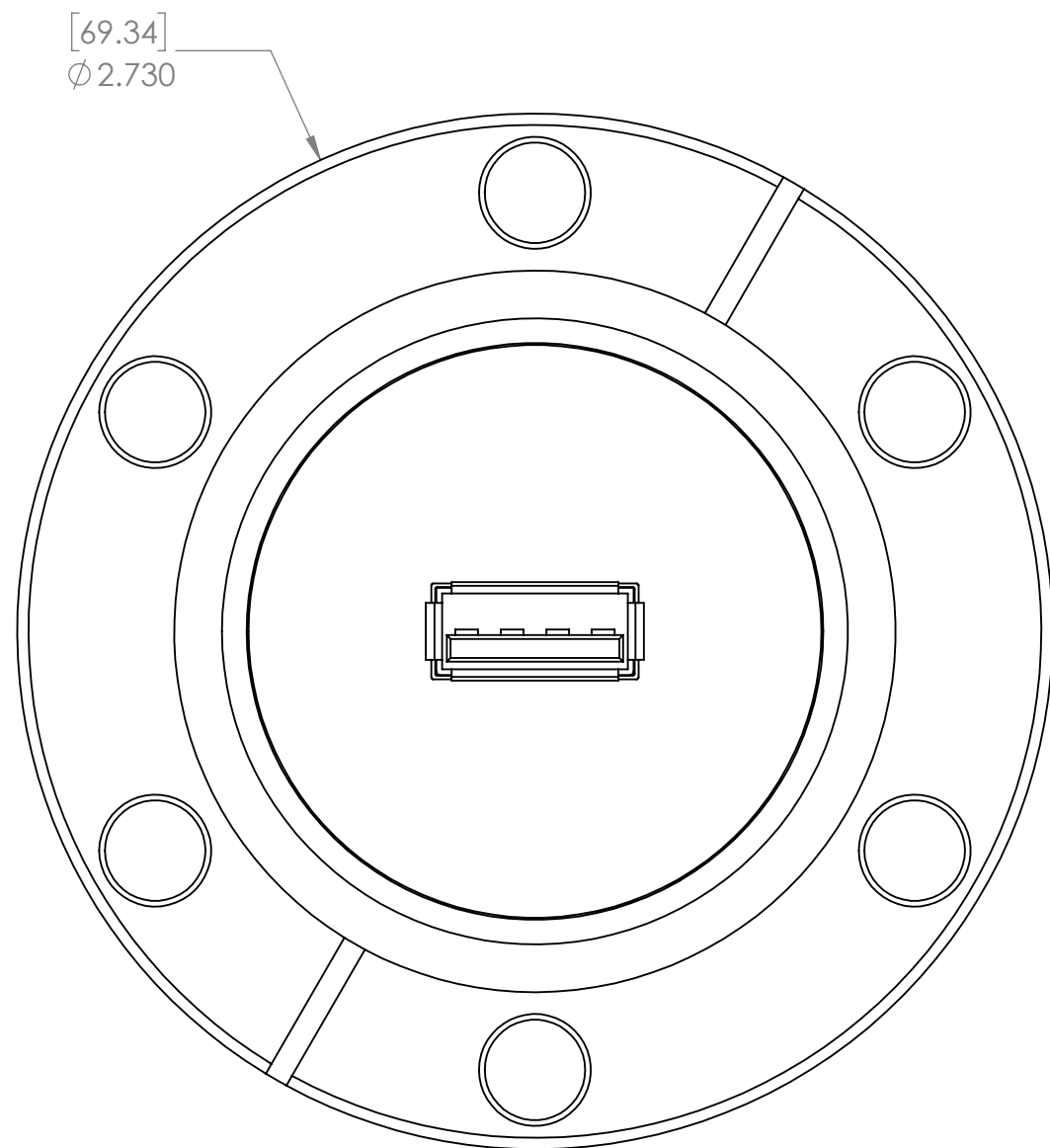

PINOUT	
HEX SIDE	THREAD SIDE
VBUS PIN 1	VBUS PIN 1
D- PIN 2	D- PIN 2
D+ PIN 3	D+ PIN 3
GROUND PIN 4	GROUND PIN 4
RECEIVE- PIN 5	SEND- PIN 8
RECEIVE+ PIN 6	SEND+ PIN 9
GROUND PIN 7	GROUND PIN 7
SEND- PIN 8	RECEIVE- PIN 5
SEND+ PIN 9	RECEIVE+ PIN 6
SHIELD	SHIELD

- NOTES:
1. HELIUM LEAK TEST 1X10⁻⁸ STD-CC/SEC OR BETTER.
 2. HIPOT 500VDC 500 MEGOHMS 1 SECOND MINIMUM.
 3. SEAL OPERATING TEMPERATURE -20C TO 130C.
 4. DIMENSIONS ARE INCHES [MILLIMETERS], MILLIMETERS SHOWN FOR REFERENCE ONLY.
 5. CUSTOM SIZES, WIRE OR FIBER OPTIC CONFIGURATIONS, & TESTS AVAILABLE, PLEASE CONTACT RHS FOR MORE INFORMATION.

UNLESS OTHERWISE SPECIFIED:
 DIMENSIONS ARE IN INCHES
 TOLERANCES:
 FRACTIONAL ±1/16
 ANGULAR ±.5
 X. ±1 .X ±.1
 .XX ±.02 .XXX ±.005

INTERPRET GEOMETRIC TOLERANCING PER:
 MATERIAL SEE ABOVE
 FINISH N/A
 DO NOT SCALE DRAWING

NAME KS
 DATE 11Apr2022
 DRAWN
 CHECKED
 ENG APPR. MN
 DATE 11Apr2022
 MFG APPR.
 Q.A.

PROPRIETARY AND CONFIDENTIAL
 THE INFORMATION CONTAINED IN THIS DRAWING IS THE SOLE PROPERTY OF RELIABLE HERMETIC SEALS. ANY REPRODUCTION IN PART OR AS A WHOLE WITHOUT THE WRITTEN PERMISSION OF RELIABLE HERMETIC SEALS IS PROHIBITED.



TITLE: CONNECTOR SEAL CF2.75 316SS USB3.0-USB3.0

SIZE B	DWG. NO. 60808	REV B
SCALE: 2:1	WEIGHT:	SHEET 1 OF 1